

# HORIZONTAL BELT CONVEYOR

CONFIGURED PRECISELY  
FOR YOUR APPLICATION

Horizontal Belt Conveyors are common conveying solutions to move product throughout your food processing plant. It's flexible, with customizations to fit your line and options to optimize sanitation, product handling, and performance. Its flat-bed stainless steel frame and tool-less belt removal allow for quick, yet thorough cleaning to keep your line moving.

- Available with thermoplastic, modular, or reinforced fabric belting
- Food-grade sanitary design with stainless steel frame
- Options to improve product handling, from tight transfer rolls to positive drive system
- Options to optimize sanitation, including belt lifts, belt scrapers and CIP Systems

## COMMON FOOD APPLICATIONS



CANDY



CEREAL



DAIRY



FRESH PRODUCE



FROZEN



MEAT



NUTS



PET FOOD



READY-TO-EAT



SNACK FOOD

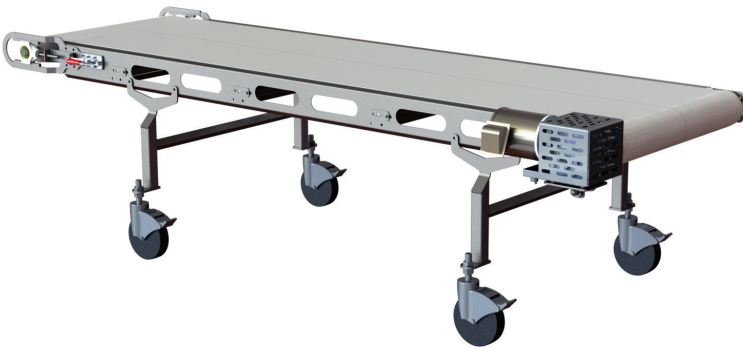

# HORIZONTAL BELT CONVEYOR

## FEATURES + SPECS

Key details to help you decide if the Horizontal Belt Conveyor is right for your operation.

- Stainless steel frame
- Belts: thermoplastic, modular, fabric reinforced, cleated
- Wash down
- Tool-less belt support removal
  
- Width: 4-96" (101-2438 mm)
- Length: 3-150' (.9-45.7 m)

## OPTIONS

Additional equipment options to customize the Horizontal Belt Conveyor precisely to your application.

- Floor, platform, or ceiling mounted
- Positive drive, sprocket, low-tension drive
- Tight transfer 5/8" or 7/8" rolling nosebars
- Pneumatic belt tracker
- Belt lifts
- Belt CIP spray bar
- Tool-less weighted belt scraper
- Infeed hopper, discharge chute

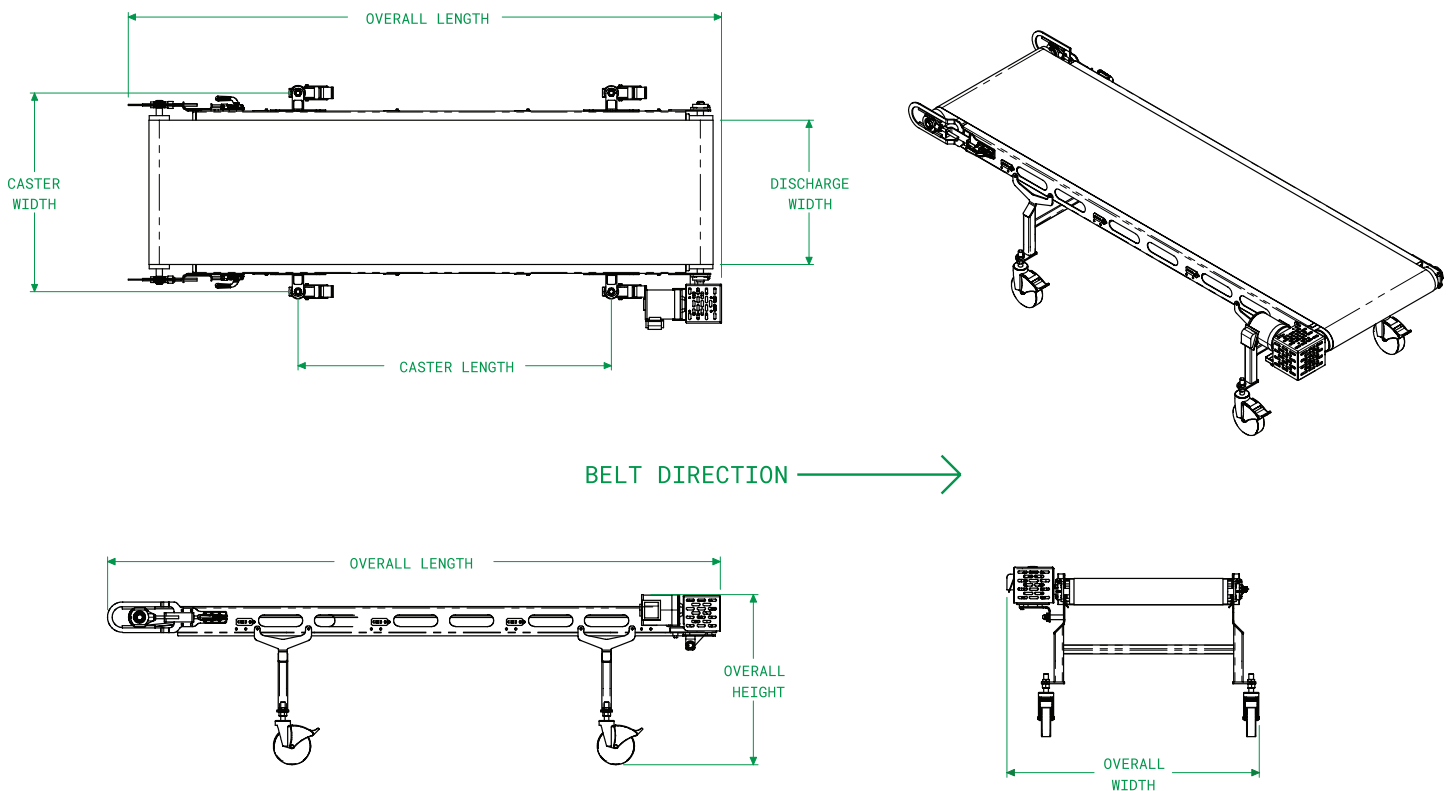

This drawing contains confidential information is the exclusive property of the J.E. Grote Co. Neither this document, nor its contents, are to be used, reproduced or disclosed in whole or in part without the express written permission of the J.E. Grote Co. Copyright 2022, J.E. Grote Company, Inc.

03.23v2

## CONTACT US

Ready to get started on your configuration?  
Contact us to customize the Horizontal Belt Conveyor to your application, layout, and processes.



To feed our growing world - Together  
sales@pficonveyors.com  
pficonveyors.com