

RETRACTOR

ADD FLEXIBILITY TO YOUR PROCESSING LINE

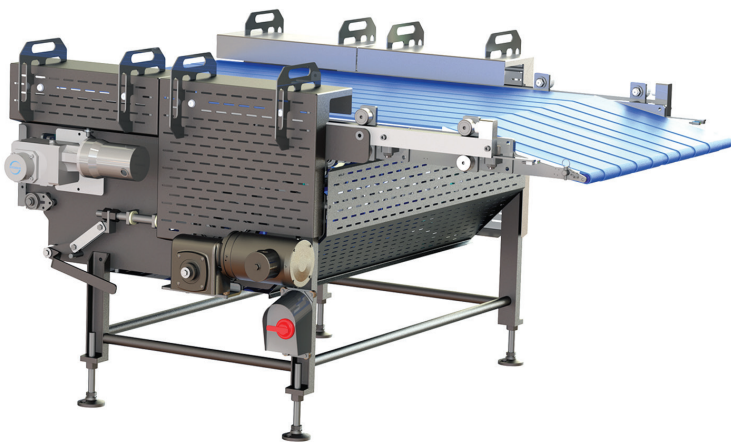

The Retractor retracting belt conveyor adds flexibility to the fixed space of your food processing plant. It performs several applications in one machine – from loading and depositing to transferring, rejecting, and positioning. Its configurable design is customized to your precise application, then servo controls are programmed to automate it. Tight infeed and outfeed transfers ensure product orientation and integrity with no damage or loss in gaps.

- Transfer, deposit into rows or stacks, position, load or reject product between key machines and processes
- Available with thermoplastic, modular, wire, or reinforced fabric belting
- Tight transfer 5/8" or 7/8" rolling nosebars for smooth, damage-free transfers
- Integrated servo controls programmed for recipes and retraction stroke lengths and speeds
- Food-grade sanitary design with positive drive system, easily removed guarding, and optional CIP System

COMMON FOOD APPLICATIONS



BAKERY



FROZEN



DAIRY



READY-TO-EAT



SNACK FOOD



RETRACTOR

FEATURES + SPECS

Key details to help you decide if the Retractor is right for your operation.

- Positive drive
- Integrated servo recipe controls
- Belts: thermoplastic, modular, wire, fabric reinforced

- Width: up to 84" (2134 mm)
- Length: application dependent
- Retracting Speed/Cycles: 150 cycles per minute

OPTIONS

Additional equipment options to customize the Retractor precisely to your application.

- Belt CIP System

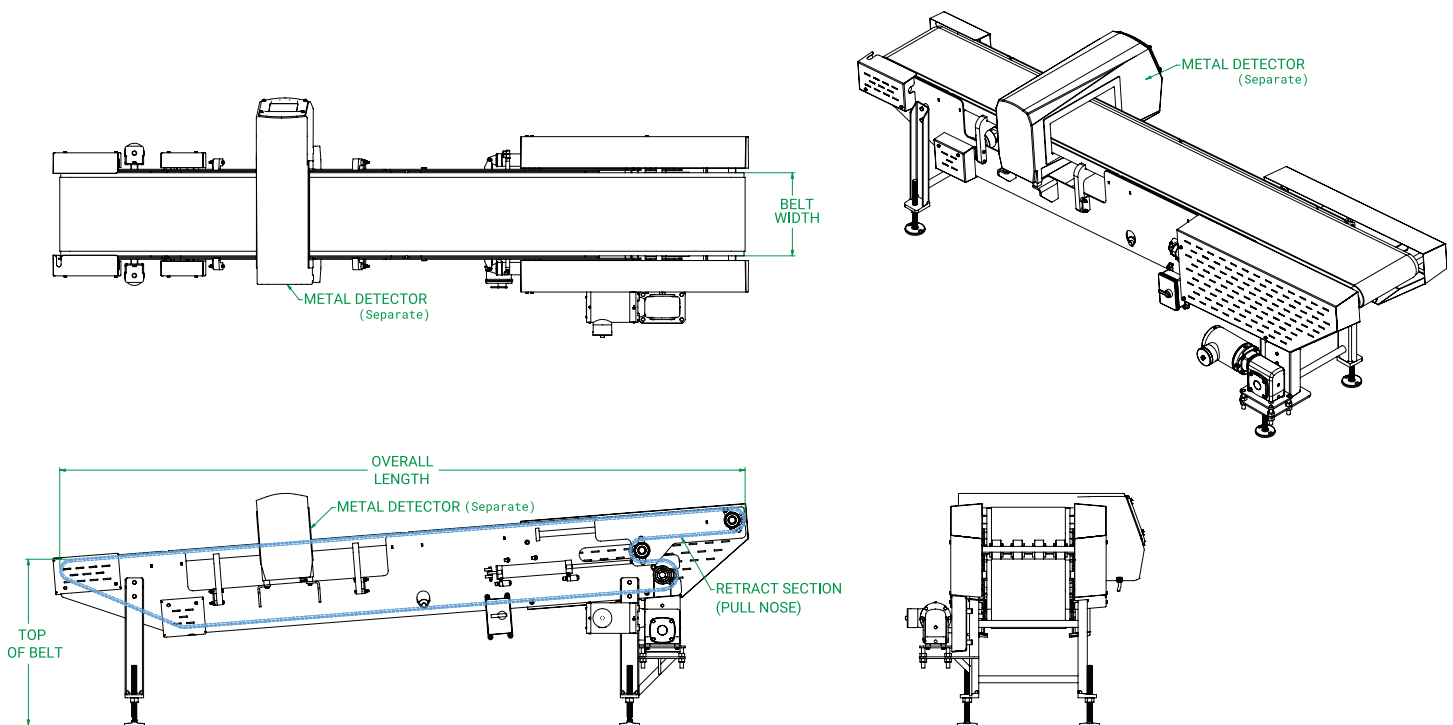

This drawing contains confidential information is the exclusive property of the J.E. Grote Co. Neither this document, nor its contents, are to be used, reproduced or disclosed in whole or in part without the express written permission of the J.E. Grote Co. Copyright 2022, J.E. Grote Company, Inc.

03.23v2

CONTACT US

Ready to get started on your configuration?
Contact us to customize the Retractor to your application, layout, and processes.



To feed our growing world - Together
sales@pficonveyors.com
pficonveyors.com