

STOREVEYOR

IN-PROCESS STORAGE TO INCREASE FLEXIBILITY AND MAINTAIN FLOW

The Storeveyor allows processors to more efficiently store and feed product throughout food processing lines. It temporarily accumulates and stores large volumes of product in a stainless steel bin, then uses belt conveyors to discharge it to the next process. It can be integrated with a range of infeed and outfeed options, including elevators, vibratory feeders, and more.

- Store bulk product inline then control discharge flow downstream
- 500-70,000 lbs. capacity
- Maintain product integrity with gentle loading, 'first in, first out' design
- Food-grade sanitary design with stainless steel construction

COMMON FOOD APPLICATIONS



CANDY



CEREAL



NUTS



PASTA



PET FOOD



SNACK FOOD

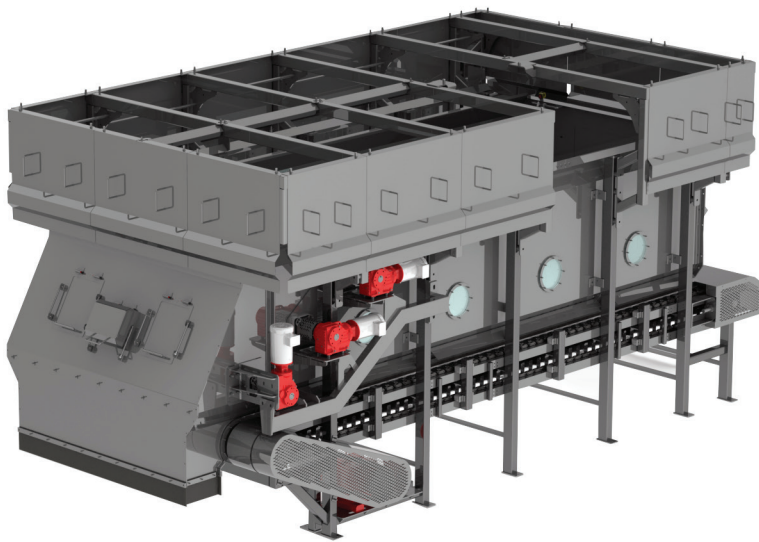

STOREVEYOR

FEATURES + SPECS

Key details to help you decide if the Storeveyor is right for your operation.

- Stainless steel construction
- Storage Capacity: 500-70,000 lbs.
- Electrical: 230/460 V/3 Ph

OPTIONS

Additional equipment options to customize the Storeveyor precisely to your application.

- Custom infeed and outfeed integrations
- Surface finishes: smooth, rigidized
- Rake or rotating fingers to move product
- Multiple belt offerings

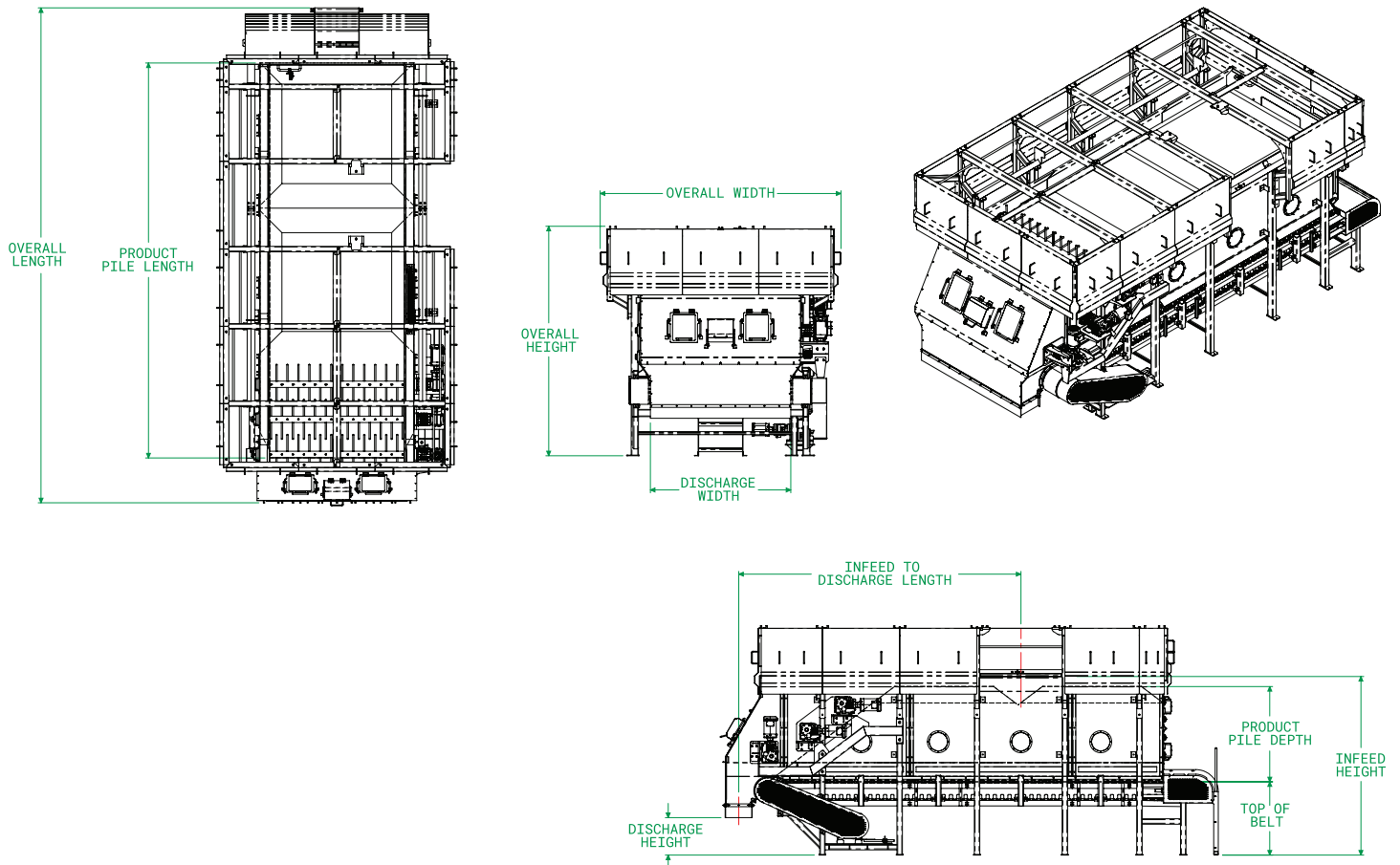

This drawing contains confidential information is the exclusive property of the J.E. Grote Co. Neither this document, nor its contents, are to be used, reproduced or disclosed in whole or in part without the express written permission of the J.E. Grote Co. Copyright 2022, J.E. Grote Company, Inc.

03.23v2

CONTACT US

Ready to get started on your configuration?
Contact us to customize the Storeveyor
to your application, layout, and processes.



To feed our growing world - Together
sales@pfconveyors.com
pfconveyors.com