

# SCREW CONVEYOR

DURABLE, SANITARY & SAFE BULK  
PRODUCT TRANSPORT



Screw conveyors are durable and sanitary to transport products throughout your food processing plant. Integrate with dumpers and more throughout your mixing, grinding, and other processes. Its flexible, available in multiple orientations, dimensions, and with options exactly for your dry or raw bulk food needs. Stainless steel construction ensures food safety and quick sanitation.

- Horizontal or incline orientation
- Available in a wide range of dimensions and pitch angles
- Configurable hoppers, discharge, and more
- Sanitary stainless steel construction with smooth, polished welds

## COMMON FOOD APPLICATIONS



CEREAL



FRESH PRODUCE



MEAT



PASTA



PET FOOD



# SCREW CONVEYOR

## FEATURES + SPECS

Details to help you decide if the Screw Conveyor is right for your operation.

- 304 stainless steel construction
- Hollow or solid auger shaft
- Horizontal or incline orientation
- Washdown
- Height, pitch angle, hopper size, discharge, all custom-configured

## OPTIONS

Additional equipment options to customize the Screw Conveyor precisely to your application.

- Variable pitch flights
- Cross agitator to avoid bridging
- Twin screw conveyor
- Casters

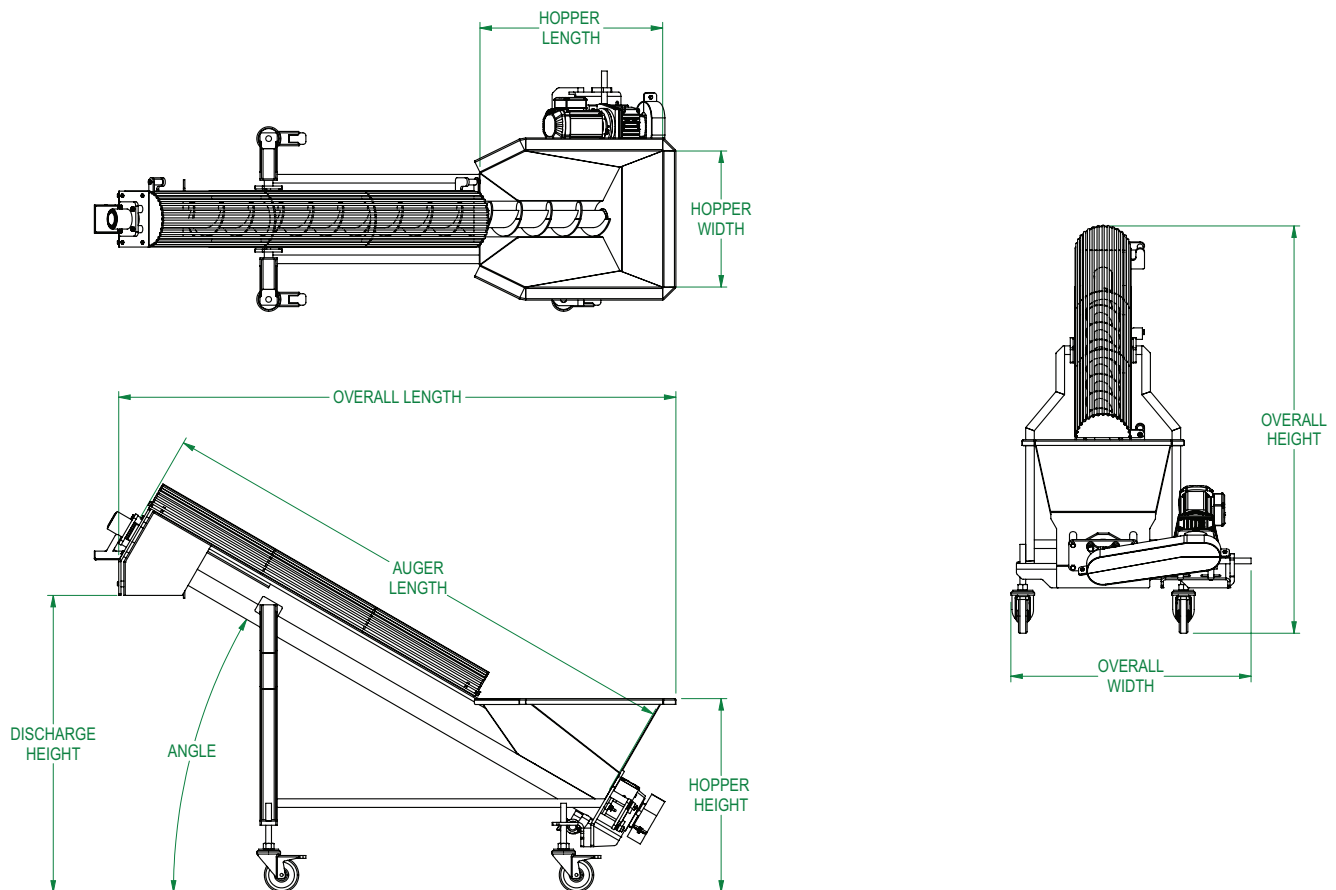

This drawing contains confidential information is the exclusive property of the J.E. Grote Co. Neither this document, nor its contents, are to be used, reproduced or disclosed in whole or in part without the express written permission of the J.E. Grote Co. Copyright 2022, J.E. Grote Company, Inc.

07.23v2

## CONTACT US

Ready to get started on your configuration?  
Contact us to customize the Screw Conveyor  
to your application, layout, and processes.



*To feed our growing world - Together*  
sales@pfi conveyors.com  
pfi conveyors.com