

# PURmotion

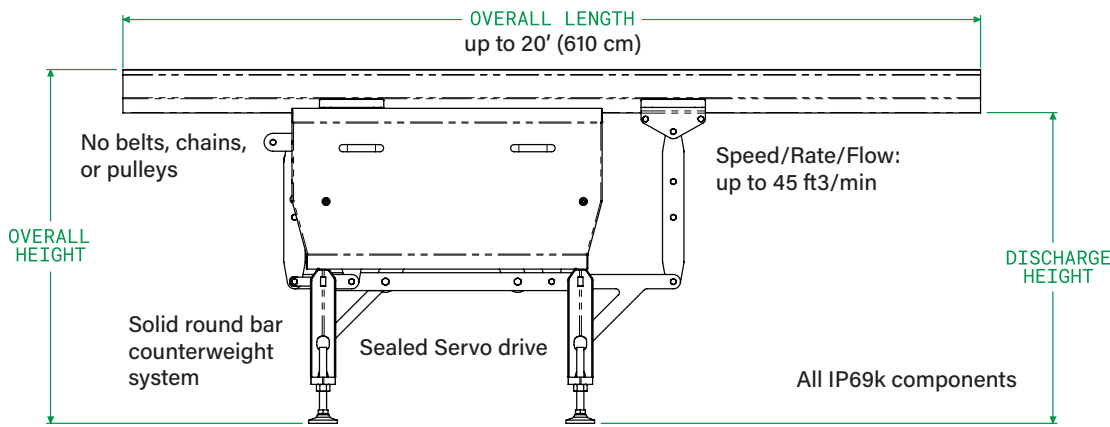

- ### FEATURES + SPECS
- Dimension ranges shown are representative. Final design is customized to your footprint and integration needs.
  - Product flow is dependent on rate, equipment dimensions, product, and system integrations.
  - Options such as configuration, sanitation levels, complementary integrations, and accessories are available and customized to your needs.

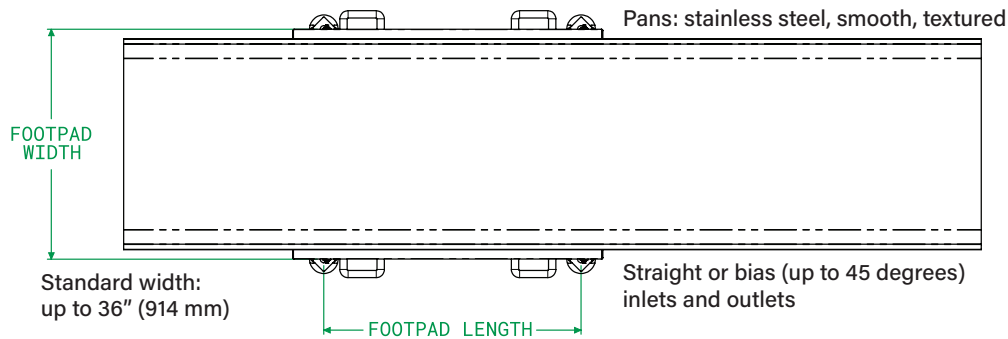
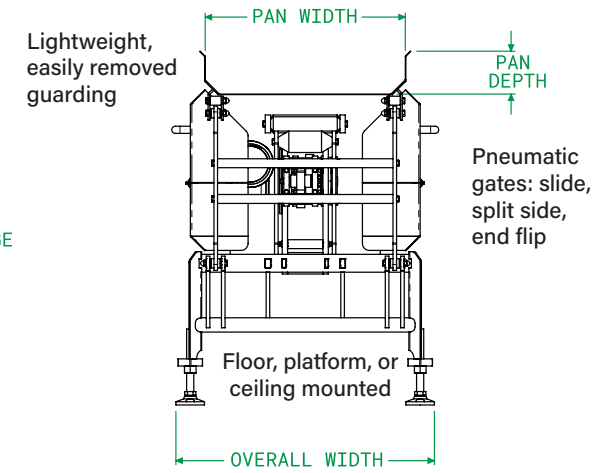

This drawing contains confidential information is the exclusive property of the J.E. Grote Co. Neither this document, nor its contents, are to be used, reproduced or disclosed in whole or in part without the express written permission of the J.E. Grote Co. Copyright 2026, J.E. Grote Company, Inc.

## CONTACT US

Ready to get started on your configuration? Contact us to customize the PURmotion to your application, layout, and processes.



sanitary conveying, delivered.™  
sales@pficonveyors.com | pficonveyors.com | +1 515 295-7265